

	PRODUCT Hot tub pergola Primary dimensions			
	NOTES All wood is #2 or better pressure treated lumber			
	DRAWN Joel Gaeddert	11/10/21	SCALE 1:50	SHEET SIZE B

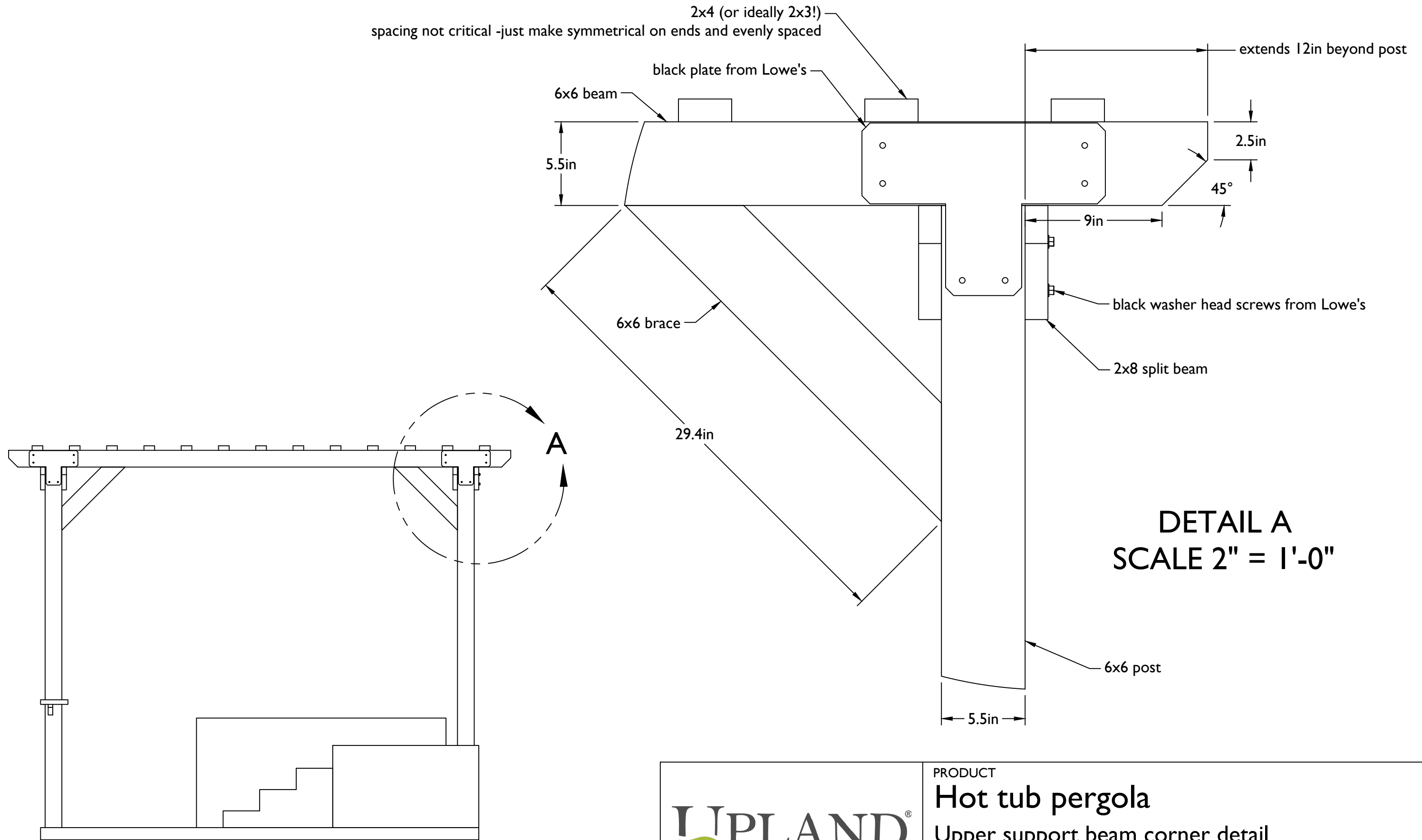

PRODUCT

Hot tub pergola

Upper support beam corner detail

NOTES

All wood is #2 or better pressure treated lumber

DRAWN Joel Gaeddert	11/10/21	SCALE 1:50	SHEET SIZE B	SHEET 2/5
---------------------	----------	------------	--------------	-----------

DETAIL E
SCALE 2" = 1'-0"

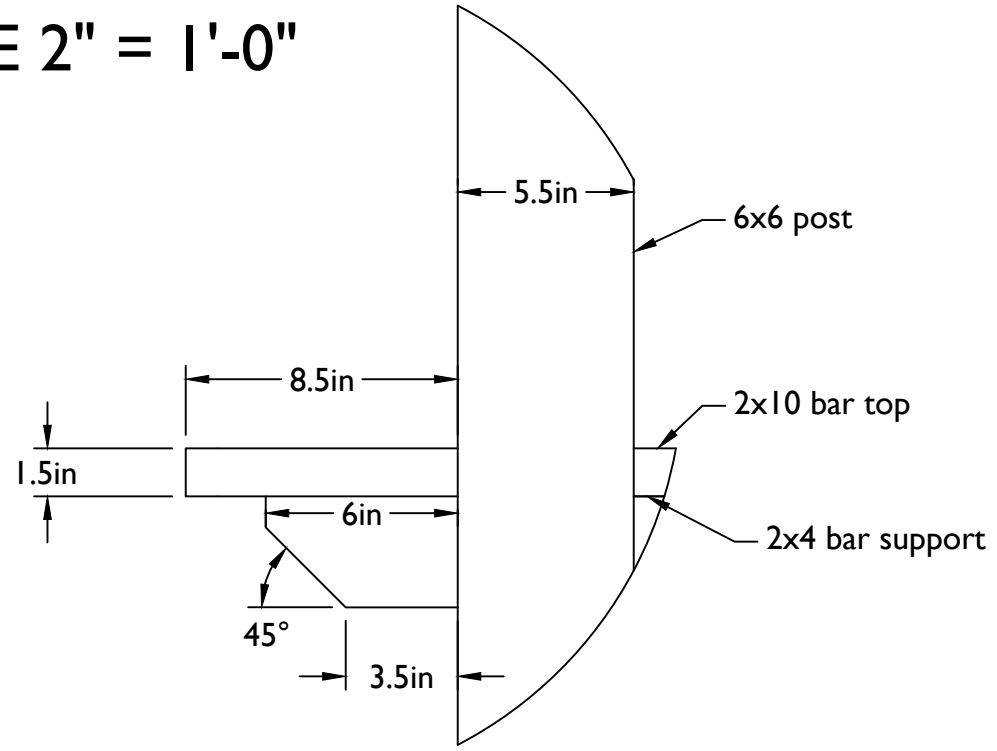

Note: upper and lower support beam braces can be identical

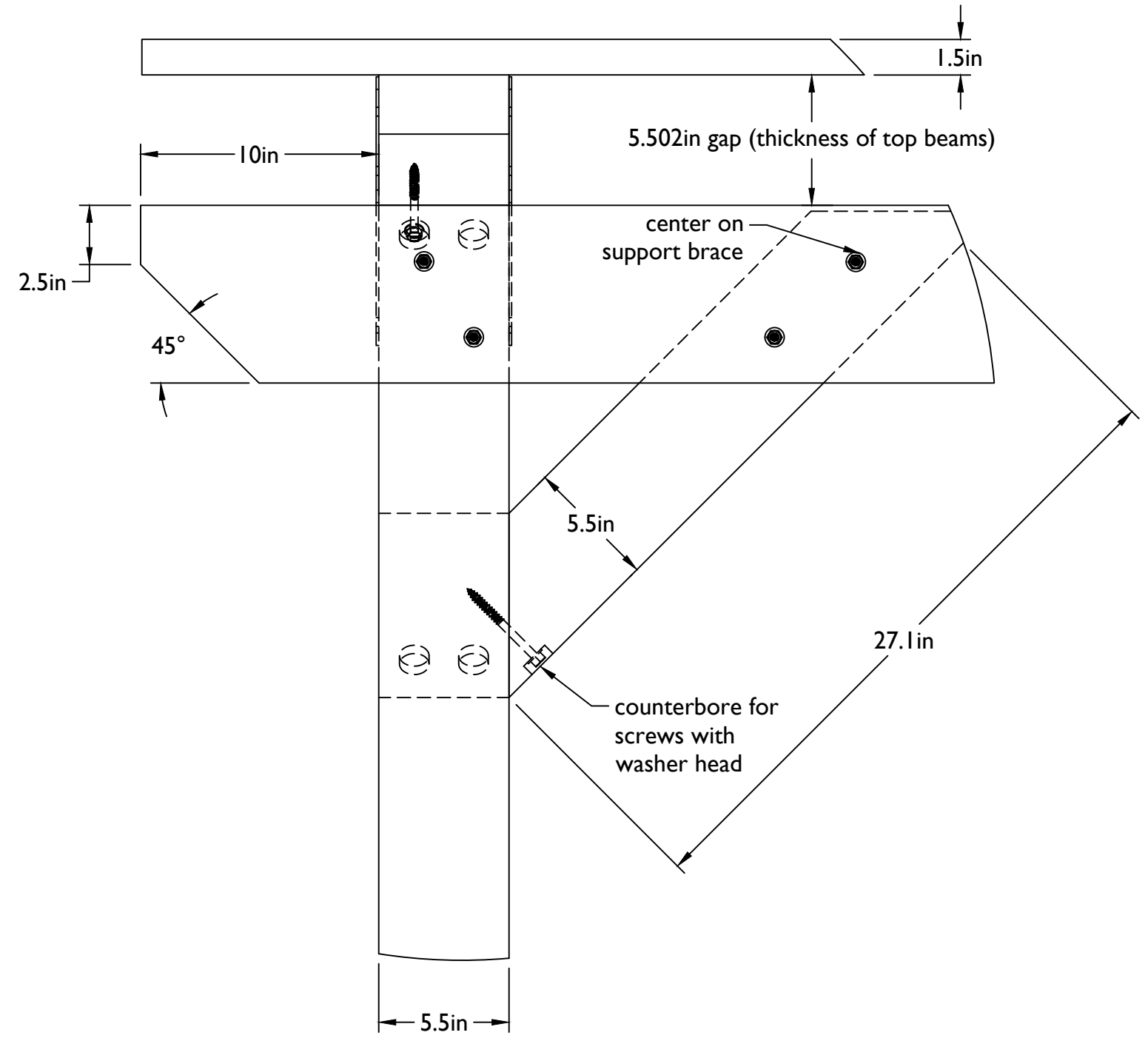
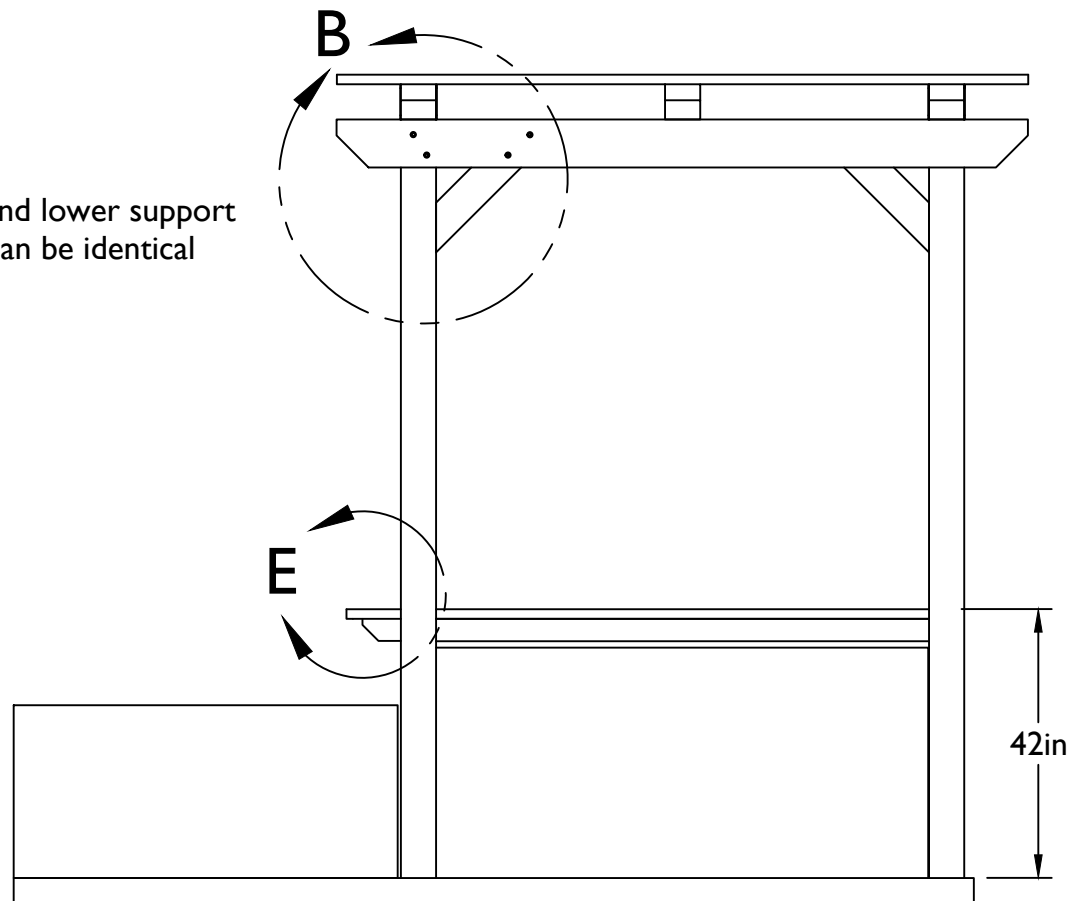

DETAIL B
SCALE 2" = 1'-0"



PRODUCT
Hot tub pergola
Lower split beam support corner detail

NOTES All wood is #2 or better pressure treated lumber				
DRAWN	Joel Gaeddert	11/10/21	SCALE	1:30
SHEET SIZE	B	SHEET	3/5	

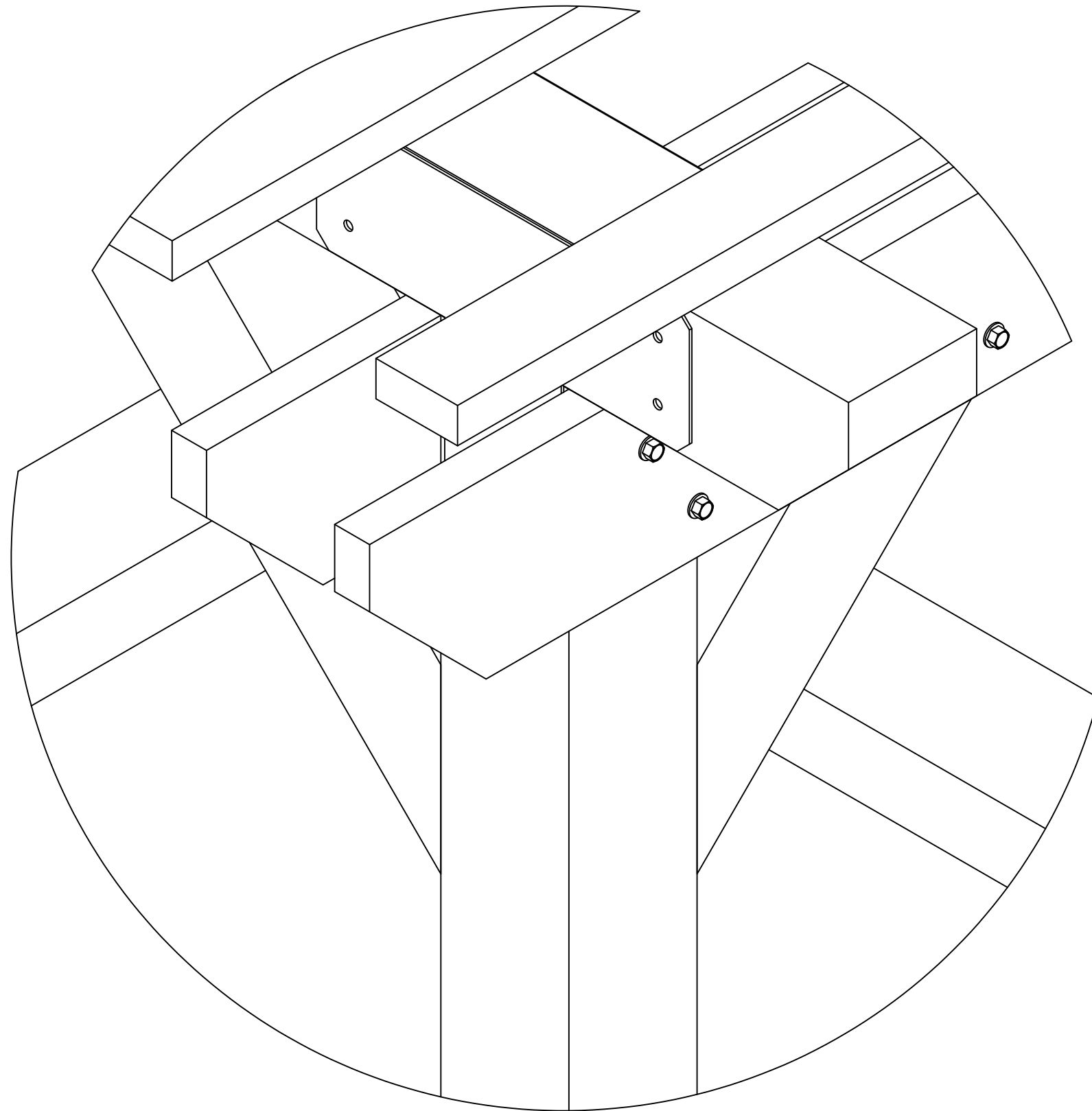

DETAIL C
SCALE 3" = 1'-0"

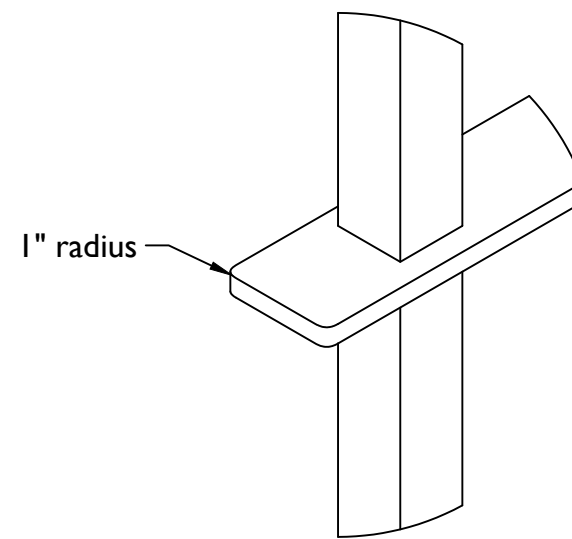

DETAIL D
SCALE 1" = 1'-0"

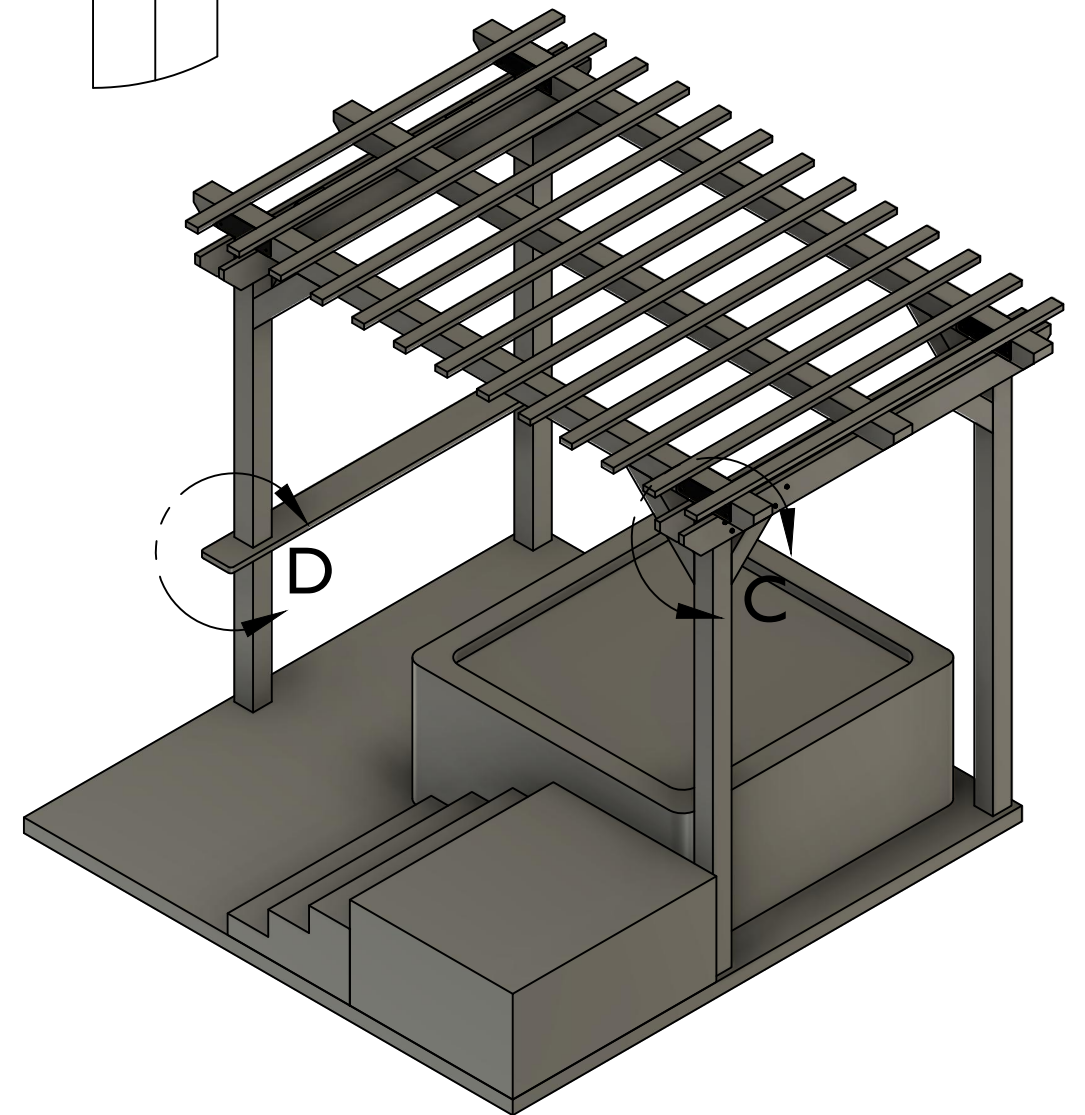

PRODUCT
Hot tub pergola

NOTES
All wood is #2 or better pressure treated lumber

DRAWN Joel Gaeddert 11/10/21 SCALE 1:40 SHEET SIZE B SHEET 4/5

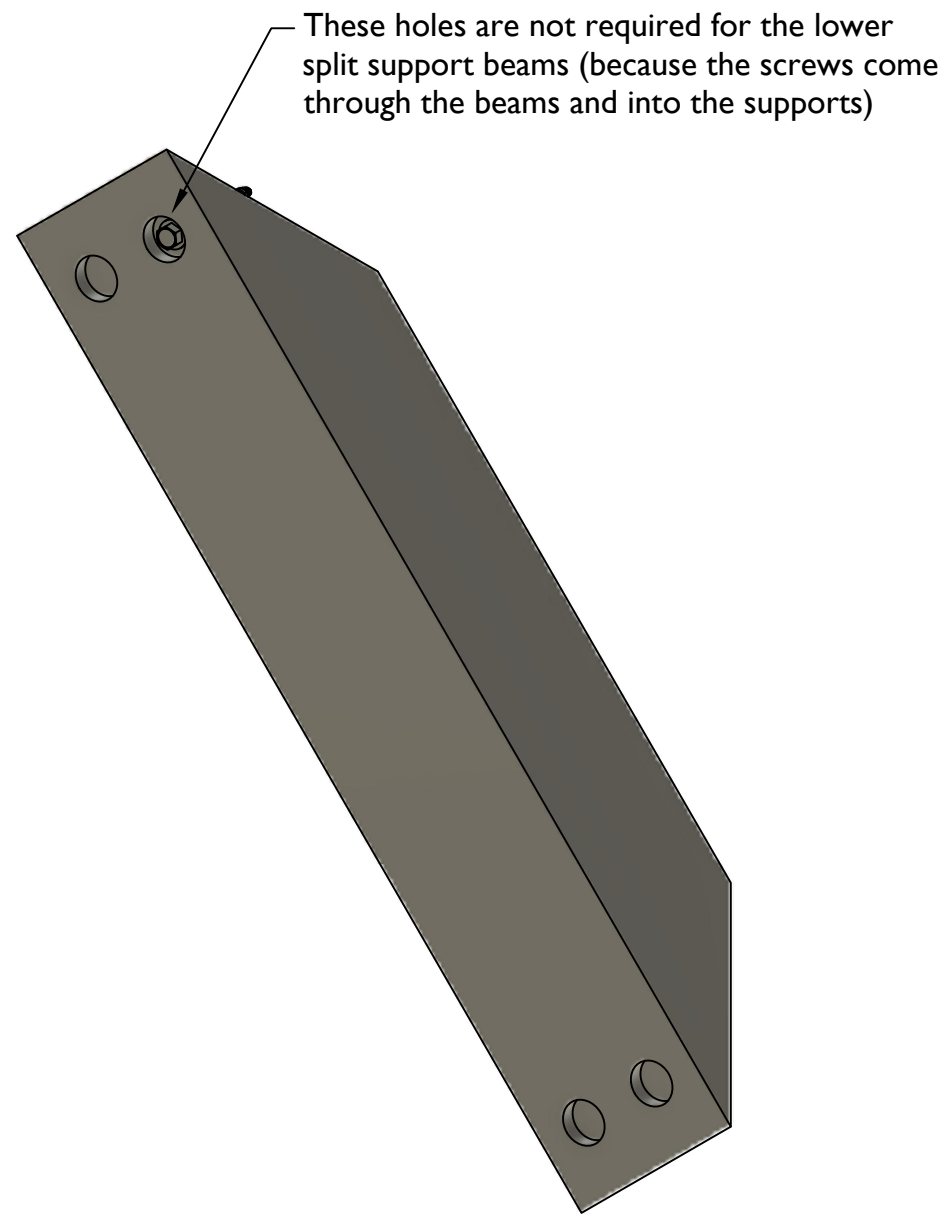

Note: counterbore is $\frac{1}{2}$ " deep or whatever feels best with final chosen washer / screw combo

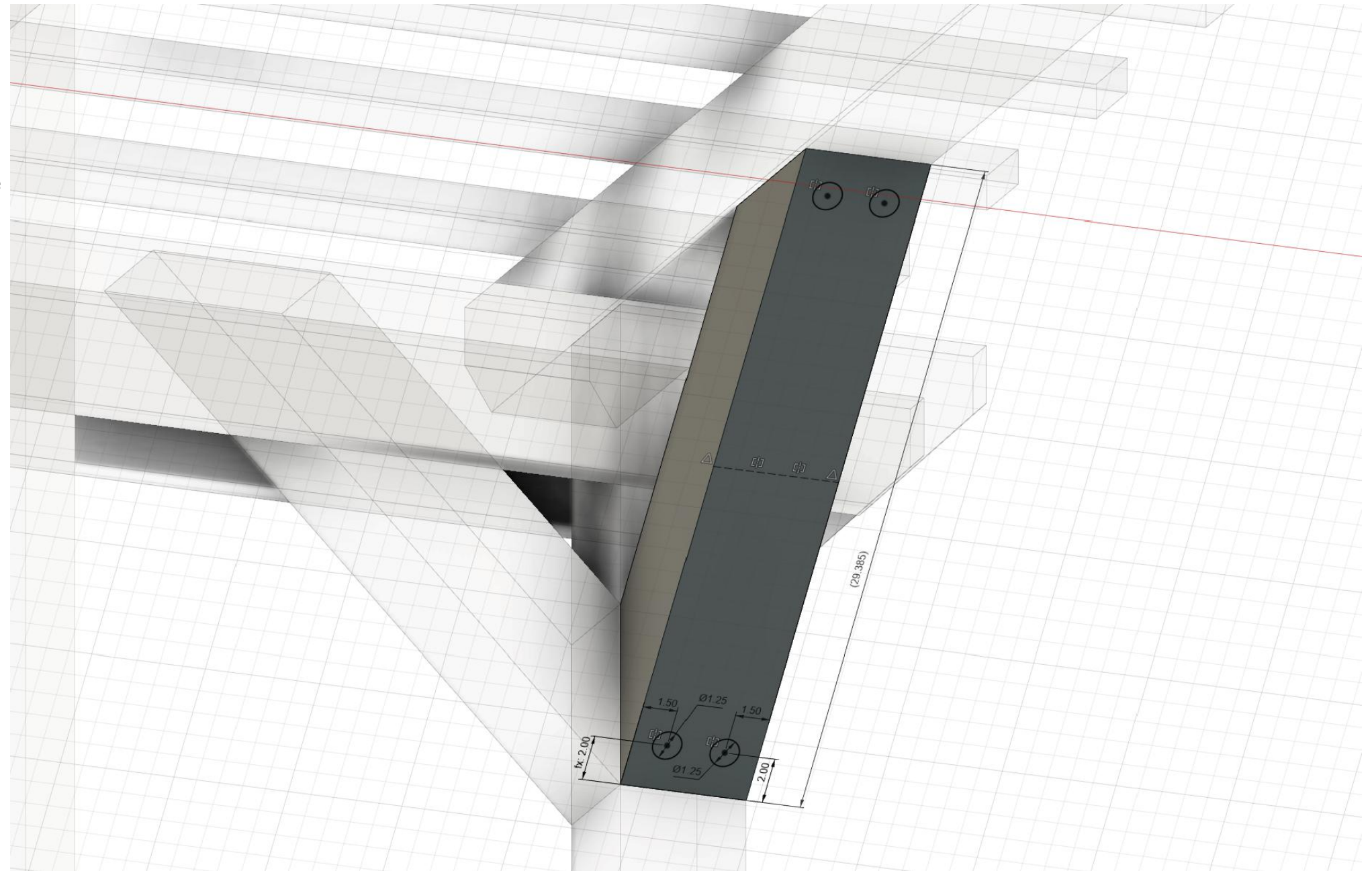

Note: dimension can be rounded down if desired (29"?) for easier fabrication and more head clearance...

	PRODUCT				
	Hot tub pergola				
	Support brace detail				
NOTES					
All wood is #2 or better pressure treated lumber					
DRAWN Joel Gaeddert	11/10/21	SCALE 1:10	SHEET SIZE B	SHEET 5/5	